

## specifications & dimensions

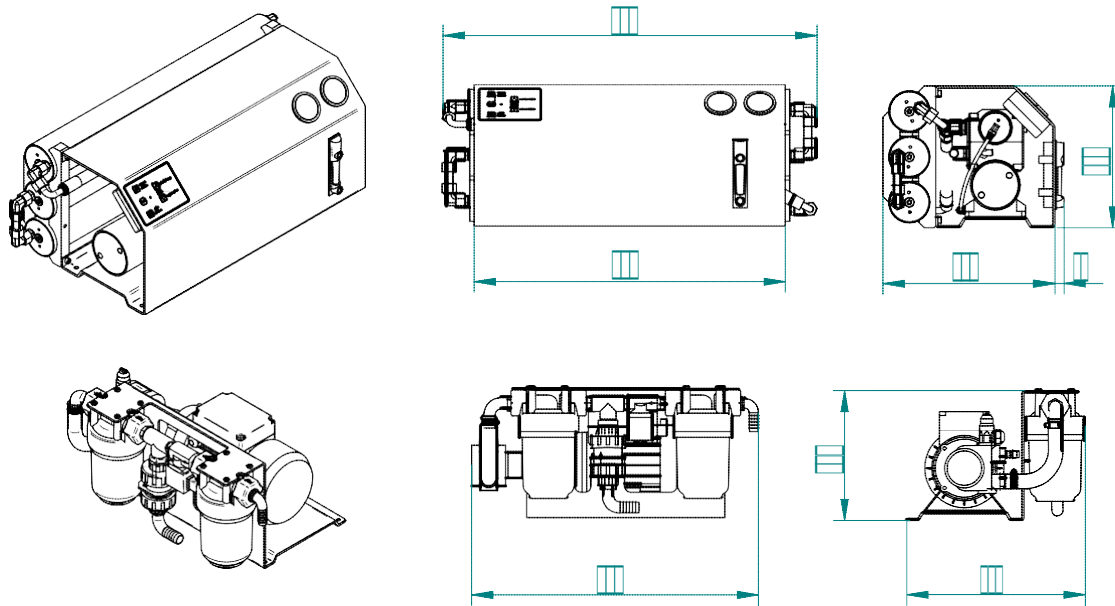

	S - 60	S - 90
Weight	41kg	46kg
Energy consumption	350w/h	540w/h
Average Amp. consumption	29a/12v - 14,6a/24v - 1,6a/220v	45a/12v - 22,5a/24v - 2,4a/220v
Booster pump minimum inlet pressure	+0,05 bar	+0,05 bar
Booster pump outlet pressure	10 - 12,5 bar	11 - 14 bar
High pressure pump outlet pressure	45 - 60 bar	45 - 60 bar
Feed Flow	600l/h	900l/h
Average effective production	60l/h (+/- 10%)	90l/h (+/- 10%)
Conversion	10%	10%
Rejected /permeated ratio	09:01	09:01
Osmotic membrane type	2 membranes 2,5" x 21"	3 membranes 2,5" x 21"



Autorized Dealer:

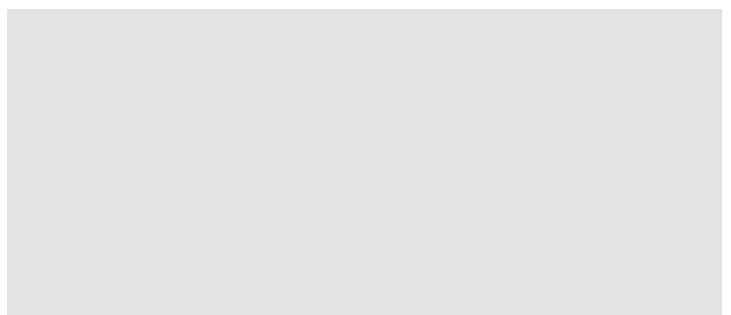

ECO-SYSTEMS WATERMAKERS S.L.

C/Horta, 22. 08203 Sabadell, Barcelona (España)

Tel: +34 937 108 950 | Fax: +34 937 122 355

Email: info@eco-systems.com

www.eco-systems.com