

## specifications & dimensions

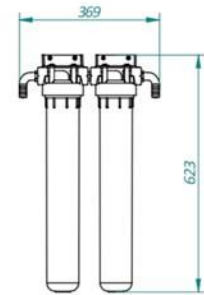

	A - 200	A - 300
Weight	68kg+12kg+2kg	75kg+12kg+2kg
Energy consumption	920w/h	1380w/h
Average Amp. consumption	4,2a/220v	4,3a/220v
Booster pump minimum inlet pressure	+0,05 bar	+0,05 bar
Booster pump outlet pressure	1 - 2 bar	1 - 2 bar
High pressure pump outlet pressure	45 - 60 bar	45 - 60 bar
Feed Flow	900 l/h	1200 l/h
Average effective production	200 l/h (+/- 10%)	300 l/h (+/- 10%)
Conversion	22%	25%
Rejected /permeated ratio	3,5 : 1	03:01
Osmotic membrane type	Fr-80-25/40 hF (3 membranes)	Fr-80-25/40 hF (4 membranes)

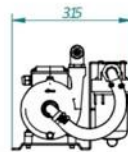
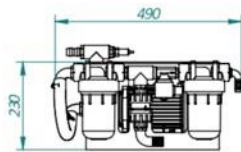
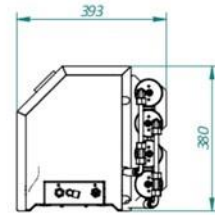
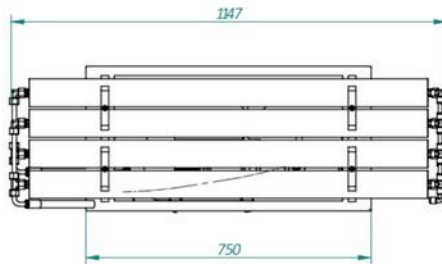
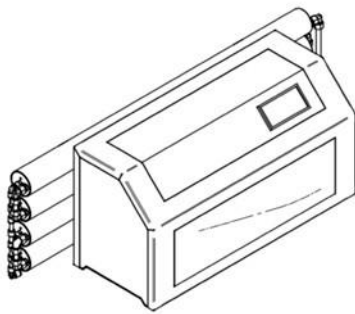

Autorized Dealer:

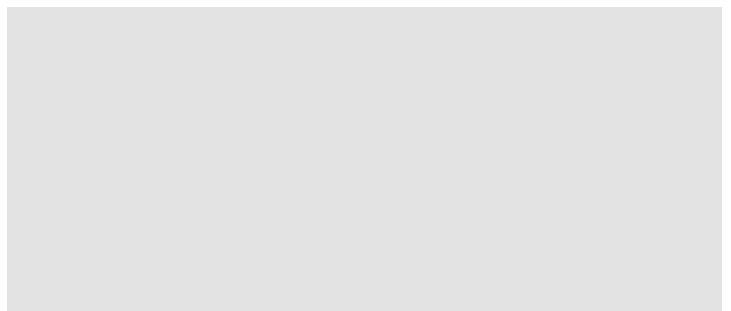

ECO-SYSTEMS WATERMAKERS S.L.

C/Horta, 22.08203 Sabadell, Barcelona (España)

Tel: +34 937 108 950 | Fax: +34 937 122 355

Email: info@eco-systems.com

www.eco-systems.com